

Sailrite Series Drogue Instructions

Coast Guard Recommendations for Series Drogue

Displacement in lbs.	#Cones	Line Lgth required		Anchor Wt. lbs.
		w/o bridle / with 75ftleader	Line Diam inches**	
Monohull				
10,000	100	246 ft.	5/8	15
15,000	107	258 ft.	5/8	15
20,000	116	138/139 ft.	3/4, 5/8	15
25,000	124	145/145 ft.	3/4, 5/8	25
30,000	132	151/152 ft.	3/4, 5/8	25
35,000	139	157/158 ft.	3/4, 5/8	25
40,000	147	110/110/112 ft.	1, 3/4, 5/8	30
45,000	156	115/115/117 ft.	1, 3/4, 5/8	40
50,000	164	120/120/121 ft.	1, 3/4, 5/8	50
Multihull				
6,000	130	296 ft.	5/8	15
12,000	140	312 ft.	5/8	15
18,000	150	166/167 ft.	3/4, 5/8	15

Line Lengths:

**Note the line may be decreased in size near the end of the drogue because of diminishing stress. When making your own drogue, if more than one line size is used, make each section roughly equal in length. And, since eye splices are used to connect different sized lines, when ordering, add an extra 4 ft. per line size for splicing. For example: for the 147 cone drogue which has a finished line length of 320 ft. you could order: 110' of 1" line, 110' of 3/4" and 112' of 5/8".

Bridle Specifications:

Each bridle leg should be 2.5 x the transom width plus a 2 ft. allowance for splicing and an appropriate length for attaching it to the boat. Bridles can be made from 3 strand line, double braided line or wire. It is often a different color to help locate it quickly. The line for the bridle should match the strength of the largest line used in the drogue.

Anchor Specifications:

In lieu of a traditional mushroom anchor, lead shot, chain or scuba weights may be used. See chart to left for recommended weights.

Complete USCG Series Drogue Findings/Recommendations:

Write or call The National Technical Information Service, US Dept. of Commerce, 5285 Port Royal Rd., Springfield, VA 22161 (ph.1-888-584-8332). Ask for Document #ADA 188 598. Cost at this printing \$31.50. Or see complete document under "Helpful Tips" on the net at www.sailrite.com.

The drogue instructions which follow are complete from sewing the cones to use of the drogue. Depending upon the drogue's stage of completion, skip to the appropriate section to begin work.

"The Series Drogue is an uncomplicated boat saver." It looks something like a parade of jellyfish in single file and consists of 100 or more five-inch-diameter cones of Ripstop Nylon Sailcloth attached every 20 inches along a long length of line. A 15 to 50 pound anchor fastened at the end of the line (to avoid snags during deployment, a mushroom anchor or rounded weight may be preferred) keeps the drogue from popping out of the water, a common problem with existing sea anchors.

This new Series Drogue was designed by U.S. Coast Guard researchers after tests showed that conventional sea anchors, which use a single large fabric parachute, are subject to fatigue failure as they fill with water and then collapse under the strains generated by storm waves. They are often destroyed before the storm calms.

The string of little cones used in the Series Drogue ensures that most are filled and working at any time, so the boat remains properly positioned for the next wave strike (*best capsizing prevention for breaking waves*). The proper position has been found to be "stern to" the oncoming waves; this keeps the boat running with the wind and waves, lessening the relative speed of the onrushing walls of water.

The new Series Drogue's steadier grip ensures that the boat's fittings are under a more-constant load, which is less likely to destroy them. In simulated fatigue testing undertaken by the Coast Guard, the drogue was subject to 15,000 cycles (the equivalent of a giant hurricane) without a failure. It still looked new and unworn, with only the cloth stiffness gone.

Drogue deployment and retrieval is easy and in most cases can be done hand-over-hand. Only in difficult storm conditions will a winch located near the transom be desirable for retrieval. (The drogue will wind on a winch just fine.)

Cone Construction

Sew 3 strips of 30" strapping to the precut cones which come with the kit. To do so lay a cone flat; then, place a strip of 3/4" strap on top of the cone (the side without seaming lines marked). Each strip will be placed so that the 11" radius of the cone (the wide end) will have 15 inches of the strap extending beyond it. The 5" radius of the cone (the narrow end) should have 9 inches of strap extending beyond it.

Follow (Figure 1) for placement of the straps and use the double sided basting tape (seamstik) to attach the straps to the cones prior to sewing. Once the straps are positioned, sew along both edges of the strap using a zigzag stitch about 1/4" wide or use a medium length straight stitch. Follow this procedure for all cones.

Now sew your cone assembly together to form a tube. Match up the straight edges of the cone. (The seaming lines should be on the outside and the straps sewn on above should be inside the cone.) Use 1/4" basting tape, if needed, to hold the edges together for sewing. Sew on the marked seaming line and then sew along the outer edge. Use straight stitches, remembering to reverse the stitches at the beginning and end of each run (Figure 2). Follow this procedure for all cones. Turn the cone assemblies rightside out when done. The straps will now be on the outside.

Cone construction (Figure 1)

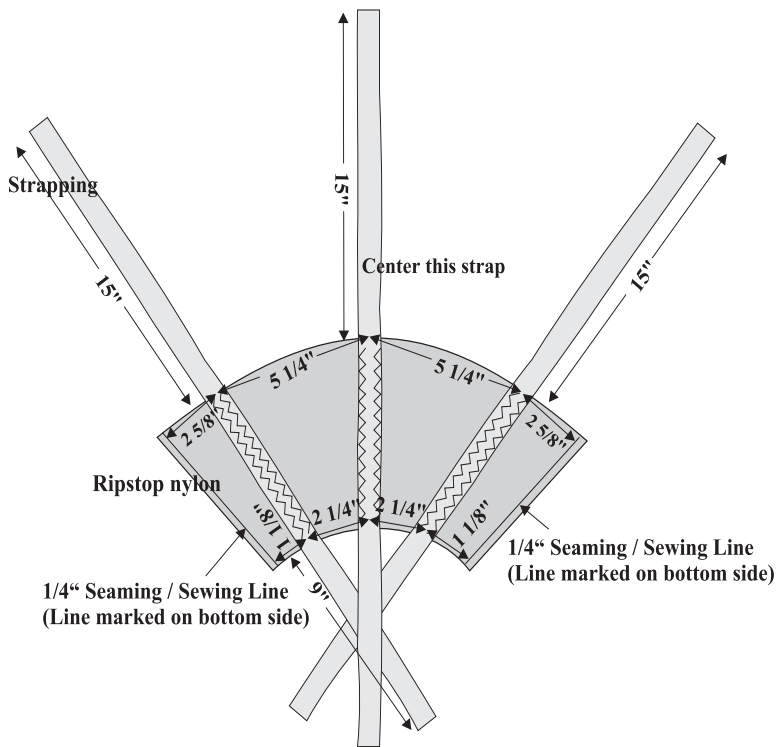

Cone construction (Figure 2)

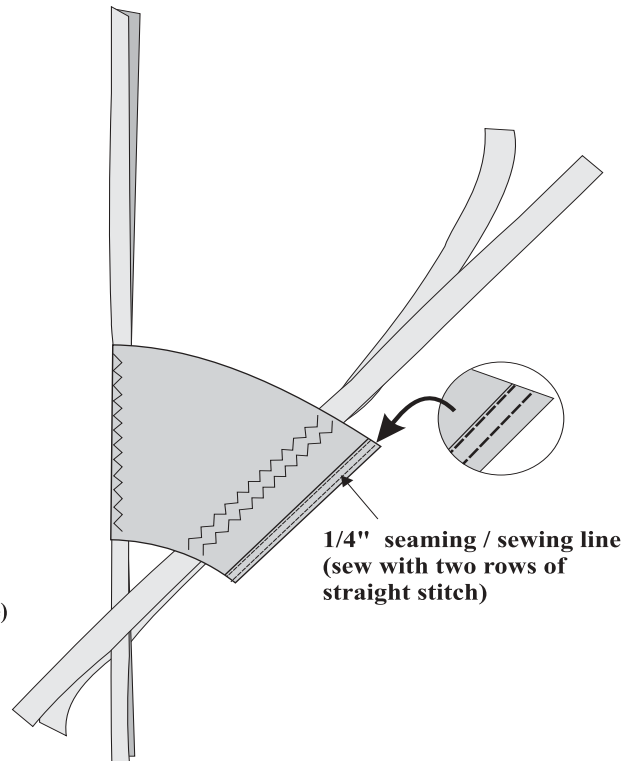

Preparing the Lines and Attaching the Cones

One or more sections of line are used for the drogue. In order to reduce the size and weight of the finished drogue, the line diameter may be decreased toward the tail end of the drogue where there is less stress. The first 75 feet of the line is the lead line. No cones are attached to this section of line as it is likely to be out of the water most of the time. The rest of the line is used for cone attachment. Follow the Coast Guard's recommendations for line size (see chart on page 1) or just use the larger line recommended for everything.

First cut the lines to the lengths specified in the chart for the boat's displacement range. Now install a thimble on one end of the smallest line. This thimble is for the attachment of the anchor (other methods for attaching the anchor to the drogue line may be used if preferred). All other line ends should have eye splices with approximately eight inch openings. These splices are used for attaching lines together and for attaching the lead line to the bridle.



To install the thimble and to make eye splices follow the simple eye splice instructions enclosed with a "Super Snake" Splicing Tool. (Note: to find marks B & C in the splicing instructions, wrap the rope around the thimble. And, in order to make a tight fit for your thimble, place marks B & C up about 1/8" from original positions. The thimble will be worked into the splice after it is complete.) Follow either the "simple eye splice" or the "compound eye splice" instructions. Note that the former splice is a bit easier for first timers. One tip from our experience. Place the overhand knot with a bight about 12 feet from mark C (instead of 6 feet). And, as soon as it is tied in place, pull the core out from the end of the rope as far as possible -- the cover will compress down toward the bight. Then smooth the cover out again so that it covers the core. If the rope was not "balanced" initially, you may find that the cover will not cover the core completely or that it will bury the core for a few inches. Cut away any excess core or cover. (if the cover is cut, it will be necessary to reestablish the B and C marks). This "balancing" procedure will make the final burying of the cross-over easier -- certainly more predictable.

Cone attachment is quickest if the line has been premarked. Stretch the line out on a flat surface under moderate tension. Start with the smallest diameter line at the thimble end. Mark the line with a felt tip pen. Make your first mark 2 feet from the thimble end. Following marks should be placed at 16 inch and 4 inch intervals as shown in Figure 3. Do not be concerned if the

Series Drogue Construction (Figure 3)

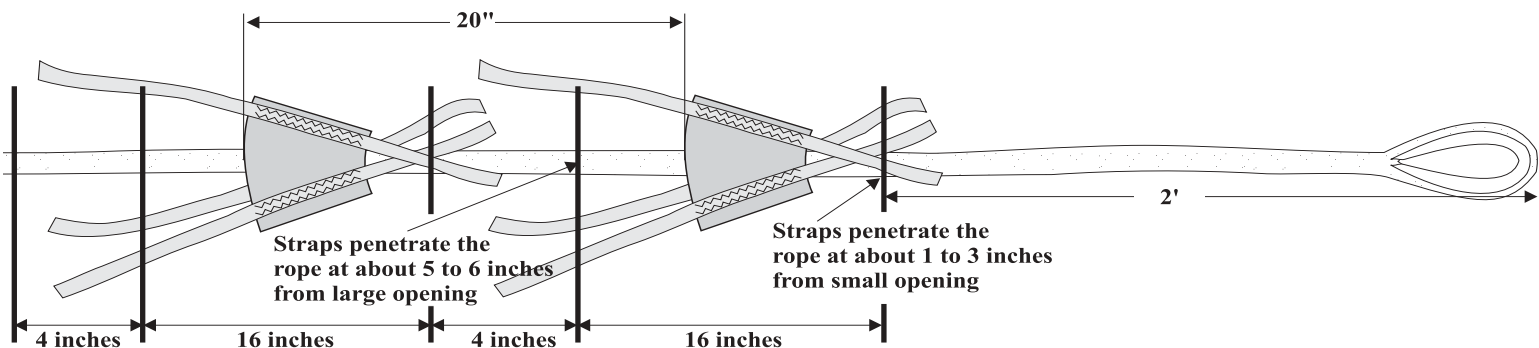

marks do not end at an even interval. If the drogue is made of more than one line diameter, follow the same procedure for each line section. Remember that approximately 75' of line at the forward end should not have marks for cones. This is the lead line.

The cones should now be attached to the drogue line(s). Position them in between the 16 inch marks. This will result in mouth-to-mouth cone spacing of approximately 20 inches.

The attachment process is tedious but does not require any special skills. The location of each cone is not critical, and tests have shown that the cones will not pull out of the braid with a variety of insertion techniques being used. On average it should take about four minutes to install a cone. Thus to install 100 cones one should allow 2 to 3 days of reasonable effort.

Slide all cones onto the line. Moving groups to their approximate locations makes things easier. Be sure all cones face the same direction and that the small end of each cone is closest to the trailing end of each line.

Cone Attachment

Attaching the cone straps to the line should be done with a Super Snake splicing tool (*see side bar for alternative method*). Insert the tool along the axis of the line as shown in Figure 4/top illustration. Place about one inch of the strap into the wire loop of the splicing tool and

Alternative Cone Attachment Method

Use of the Super Snake splicing tool to pull the straps through the line works well but can take a lot of time. And the masking tape to hold the strap to the tool can be a sticky mess. An alternative method is to create your own wire tool for strap insertion. An oversized paper clip (about 2" long) can be straightened and re-bent to look like a tall "U". The radius at the bend should be about 1/8". Or use a fairly stiff small diameter wire to fashion the tool.

Insert the tool along the axis of the line as shown in Figure 4/bottom illustration. Pass the tools bent end under about 4 to 6 strands of the outer braid only. Move the tool until you can feel that it is under the outer braid; then, rotate the tool until it is at 45 degrees to the axis of the line and push it through the braid as shown in Figure 5/bottom illustration. Now pass about two inches of a cone strap through the open bent end of the wire tool. Pulling the tool back out will then pull the strap through the braid. Note: it is not necessary or desirable to pass the strap through both the inner core and outer braid of the line.

Insert the straps at the small end of the cones first. When inserting the straps at the small end of the cone, insert the tool so that it is angled toward the small end of the cone. At the large end of the cone, insert the tool angled toward the large cone end (Figure 6/bottom illustration).

now continue on page 6

Figure 4
Attaching Cones

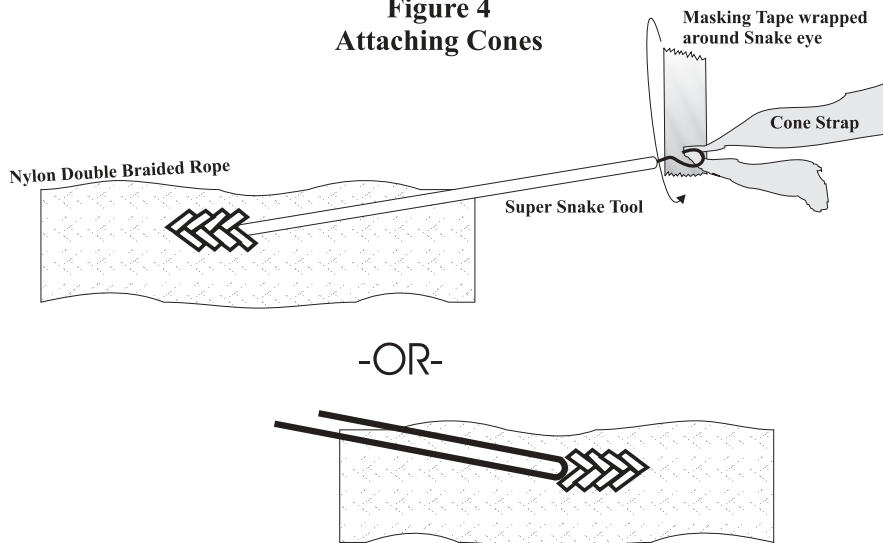

wrap with masking tape to form a smoother transition between the tool and the strap. Pass the tool end under about 4 to 6 strands of the outer braid only. Move the tool until you can feel that it is cleanly under the outer braid; then, rotate the tool until it is at 45 degrees to the axis of the line and push it out through the

**Figure 5
Attaching Cones**

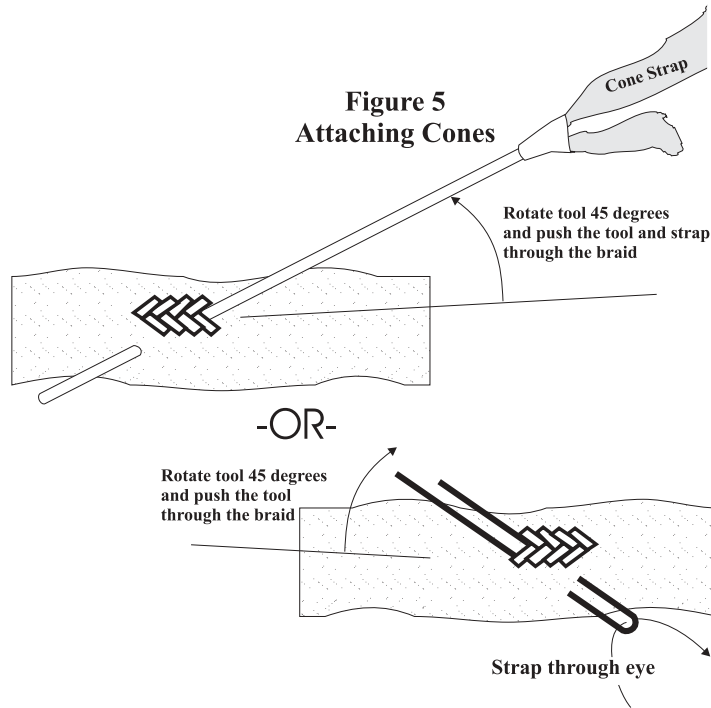

**Figure 6
Attaching Cones**

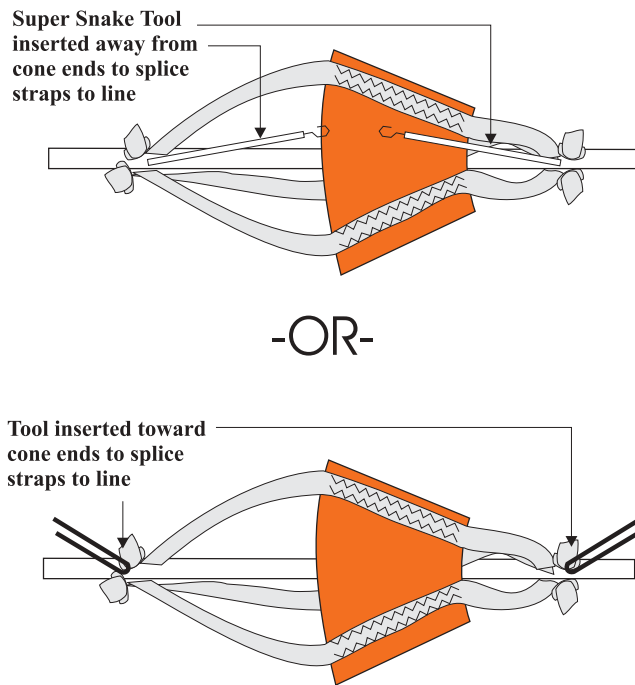
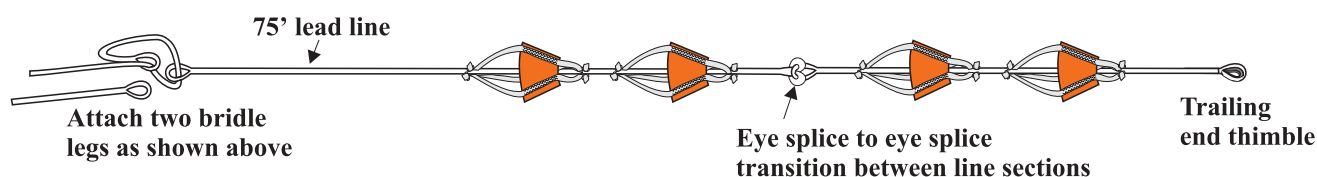

Figure 7
Drogue Assembly



braid as shown in Figure 5/top illustration. Pull the tool through the braid until only the strap is in the braid. The strap should be inserted under the outer braid only. Remove the tape and go on to the next strap. It is not necessary or desirable to pass the strap through both the inner core and the outer braid of the line.

Insert the straps at the small end of the cones first. When inserting the straps at the small end of the cone, insert the tool so that it is angled away from the small end of the cone. At the large end of the cone, insert the tool angled away from the large cone end (Figure 6/top illustration).

Three straps on each cone end must be spliced to the line. Insert the first strap, then rotate the line about 1/3rd turn for the next strap. And another 1/3rd rotation for the third strap. Pull all straps through and tie "Figure Eight Knots" in each strap. There should be 1 to 3 inches between the knots and the small end of the cone. At the large end of the cone there should be about 2 to 3 inches slack in the straps when the drogue line is taut. The slack allows the mouth of the cone to open fully underwater.

Due to stresses on the straps at the large end of the cone it is recommended that an "Overhand Knot" be tied over the Figure Eight Knot to be sure that the straps will not pull through the braid.

After the cones are attached, join the sections of line together by passing the forward end of the first line through the forward eye end of the second line and then through the trailing eye end of the first line. Snug the lines to cinch the connection tightly. Remember that larger diameter lines are followed by the smaller diameter sections. Make sure the cones all face the same direction with the large mouth of each cone

forward. The two bridle legs can also be attached this way (Figure 7).

Bridle Attachment

- Attach to furthest aft and outboard corners of a monohull.
- Attach to furthest aft or forward and outboard corners of a catamaran or trimaran.
- Attach to fitting of adequate strength with secondary attachment to distribute the load to the hull structure.
- Attach the bridle so as to reduce chafe (do not use fairleads unless absolutely necessary).
- Be sure that the cockpit area and its hatches/doors can withstand a water jet velocity of 15ft/sec.

Drogue Deployment

- 1) Attach the bridle to the boat making sure they are not twisted.
- 2) Attach the anchor to the drogue end and slip overboard to pay out the drogue. This can be done from a lazarette or a special drogue storage bag secured on deck.
- 3) Once the drogue is set, the cones will fill and begin to produce a drag. Steerage will be lost so the rudder should be locked amidship.
- 4) Crew and helmsman should go below.

Drogue Retrieval

Retrieval of the series drogue is usually accomplished hand-over-hand. The load will be significantly less than the working load during a storm. Further reduction of the load can be achieved by heading into the seas so that the drogue's velocity relative to the water is zero.

In extreme cases a winch may be used for retrieval. The drogue will compress around the winch without damage to its integrity.

Other Uses for the Series Drogue

- In an emergency use the drogue as part of a ground tackle rode.
- The drogue can be deployed to stabilize a rolling boat to go aloft.
- The drogue can be used to decrease drift toward a lee shore when the boat is disabled.

Drogue Care

- Keep the drogue out of sunlight to prevent ultraviolet deterioration.
- Once soaked in saltwater, wash and rinse in fresh water to prevent the formation of salt crystals which can damage the fabric fibers.

**TO PURCHASERS
OF THE SAILRITE SERIES DROGUE**

Please determine prior to use whether this drag device is suitable, adequate, or safe for the use intended. Since individual applications are subject to great variation Sailrite makes no representation or warranty as to the suitability or fitness of the series drogue for any specific application.

DISCLAIMER OF IMPLIED WARRANTIES:

The goods covered by this contract are purchased by the Buyer "as is" and the Seller does not warrant that they are of merchantable quality nor that they can be used for any particular purpose desired by the Buyer.

DISCLAIMER OF EXPRESS WARRANTIES:

It is hereby agreed that any description of the goods contained in this agreement is for the sole purpose of identifying them, it is not part of the basis of the bargain, and does not constitute a warranty that the goods shall conform to that description; that the use of any sample or model in connection with this contract is for illustrative purposes only, is not part of the basis of the bargain, and is not construed as a warranty that the goods will conform to the sample or model; and that no affirmation of fact or promise made by the Seller, whether or not in this agreement, shall constitute a warranty that the goods will conform to the affirmation or promise.



Self-Reliance Under Sail

©1998

Sailrite Enterprises, Inc.
4506 S. State Rd. 9-57
Churubusco, IN 46723
Phone (260)693-2242
Fax (260)693-2246
800-348-2769
email: sailrite@sailrite.com
www.sailrite.com
All rights reserved.

Donald J. Jordan
Consulting Engineer
113 Evergreen Lane
Glastonbury, Connecticut

Structural Requirements for Series Drogue Attachments

Dear Skippers,

I am sending this note to all purchasers of the series drogue for whom I have addresses. I want to make sure that you all have a clear understanding of the loads that the drogue may impose on the boat at the attachment points.

Several boats have ridden out severe storms including one hurricane with the drogue deployed. The drogue performed as it should. The crews reported that they did not feel threatened and the drogue loads appeared to be moderate. However, none of the boats was struck by a dangerous breaking wave such as capsized the yachts in the Fastnet storm or the recent New Zealand storm. On some of the boats which used a series drogue the bridle was led through a chock and belayed on a sheet winch. This arrangement is suitable for non breaking waves but it may not be adequate for a dangerous breaking wave.

For a boat displacing 30,000 lbs. model tests and computer simulation predict that the drogue can generate a force approaching 20,000 lbs. when struck by a very powerful (and fortunately extremely rare) breaking wave. The tests also show that when the boat is struck on the quarter, one leg of the bridle will be subjected to 70% or 14,000 lbs. Thus the attachment point should have the capability of carrying a once in a lifetime load of this magnitude.

I have no information on the ultimate strength of a typical sheet winch installation and it would be difficult to evaluate each unique mounting. Unfortunately a winch (or a cleat) is not an ideal structure, since the load is applied above the deck line and tends to overturn the winch and tear it out of the deck. The optimum attachment for the drogue is clearly a strap similar to a chain plate, bolted to the hull at the corners of the transom as shown in the sketch. This arrangement feeds the load directly

into the hull and imposes no bending or pullout loads on the hull or deck. For a load of 14,000 lbs. a strap 1/4 x 2.25 x 18 inches attached by six 3/8 inch bolts would provide a conservative design.

Such a strap is relatively inexpensive and should not be difficult to install. You may never need it but it is prudent policy to insure that the full capability of your series drogue can be achieved.

Miles Smeeton in his book "Once Is Enough", which many of you have probably read, presents one of the best descriptions of the power and unpredictability of a breaking wave. It is this extreme case that the series drogue is developed to handle.

Listed below is a table of design loads for a single bridle attachment. These loads are believed to be the worst case loads with some margin. However, since the loads are determined by the size and shape of the worst wave there remains some uncertainty as is the case with many natural phenomena.

Displacement	Single Bridle Load lbs.
10,000	5,000
20,000	10,000
30,000	14,000
40,000	17,500
50,000	21,000

I would welcome any comments or suggestions.

Pleasant sailing,
Donald J. Jordan

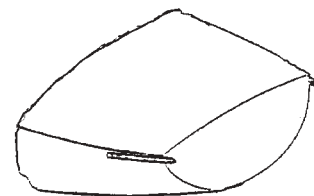

Series Drogue
Bridle Design Reqmts.

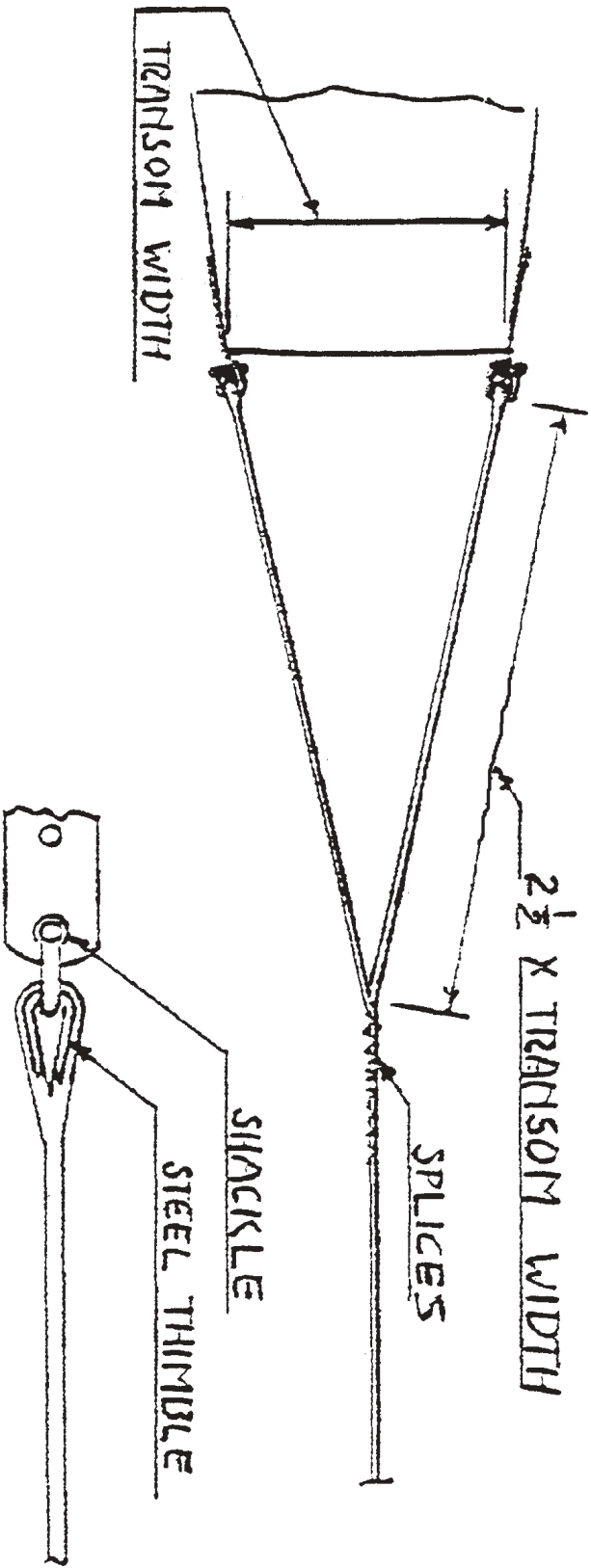

Displace	Total Load	Bridle Load	Rope Diam.	Shackle Size
10,000	8,000	5,000	5/8	3/8
20,000	14,000	10,000	5/8-3/4	1/2
30,000	20,000	14,000	3/4	5/8
40,000	25,000	17,500	7/8	3/4
50,000	30,000	21,000	7/8	3/4

Don Jordan

Notes on the Series Drogue

By Don Jordan, inventor, retired aeronautical engineer

The series drogue was developed to perform two separate functions:

1. To prevent the capsize of monohull and multihull sailboats in the event of a large breaking wave strike.
2. To improve the motion of the boat in storm waves and to reduce drift.

Most storms do not generate dangerous breaking waves. A vessel may go through a lifetime of cruising without being struck by a breaking wave even though hurricane winds have been encountered.

Although storm waves move at speeds up to 30 knots, the water in the waves moves at a much lower speed. A boat lying ahull is not subjected to high forces. Experience and testing have shown that a well found monohull with positive stability at 90 degrees roll angle has little risk of being dragged by non-breaking storm waves. A multihull, however, may be capsized.

A dangerous breaking wave is formed by the interaction of two or more storm waves. This type of wave has a large mass of water at its crest moving at wave speed (20-30 knots). When a vessel lying ahull is struck by this moving mass of water, a very large force is developed. In a typical event the boat has been successfully riding out the storm for many hours, then, 10 seconds later it lies dismasted and damaged. It is the function of the drogue to turn the stern into this moving mass of water and pull it safely through.

The risk of breaking wave capsize is dependent on the weight of the vessel, with small light boats being at high risk. Above a length of 40' the risk is diminished, and above 60' few, if any breaking wave capsizes are on record.

On a conventional monohull sailing yacht the underwater lateral surface is located aft of the center of the boat while the topside area is greater towards the bow. When struck by a moving mass of water the bow of such a vessel is driven down by a powerful turning moment. Therefore, it is necessary

to use a drogue from the stern rather than a sea anchor from the bow to align the boat with the moving water and pull the boat through.

A multihull is relatively symmetrical fore and aft, although there is still some tendency for the bow to be driven down by the wave. Testing indicates that either a drogue or sea anchor, if properly designed, can be effective in preventing breaking wave capsize. However, the force required of the drogue is less than that required of a sea anchor.

Some sailors have expressed reluctance to use a drogue for fear of being "pooped". Testing has shown that a conventional monohull or multihull will perform in a safe manner when riding stern to the sea. Actually, the stern generally has more local buoyancy than the bow and will rise quickly to a steep sea. However, storm waves will have whitecaps containing some moving water and this may splash aboard. In a dangerous breaking wave strike, moving water may sweep the cockpit and strike the companionway doors. This is unavoidable, and is a necessary corollary to saving the vessel.

Recovery: The crew of a 40' ketch practiced several methods of taking in the drogue in a Force 7 wind in the English Channel. They concluded that the best system was to grind it in with a cockpit winch a little at a time, letting the sea help you and belaying when the pull was high. With a little care they avoided tearing any cones. Another system is to prepare two helper lines, clamp one line on the drogue and winch in 3 or 4 feet, then repeat with the other line. This takes 20 minutes or so, but is safe and not particularly difficult.

Adding a light line in parallel with the drogue to permit the drogue to be pulled in backwards is definitely not recommended since it complicates the gear and may lead to fouling under critical conditions.

email: donaldjordan@worldnet.att.net
Phone: 1-860-633-1702
Mail: 113 Evergreen Lane
Glastonbury, CT 06033